



Miami Stack Table

- Master pack 6.
- 2.8 Lbs.
- 17" x 17" Square.
- One piece construction.
- 100% Prime resin.
- Stacks for storage.
- UV inhibitors
- \$50.00 charge for orders under \$500.00.
- \$50.00 charge for quantities other than the master pack.

Item #: GR MST6

Resin Colors



Bronze Mist



Sandstone



White



Charcoal

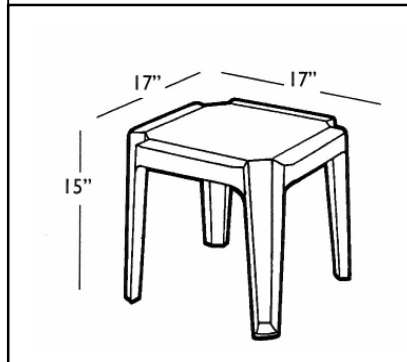

NATIONAL OUTDOOR FURNITURE, INC.
 1210 W. Main Street #296. Riverhead, NY 11901
 Toll-Free Phone: 1-888-663-4621
 Phone: 631-369-9099 Fax: 631-207-8312
 Email: nofinc@optonline.net
www.nationaloutdoorfurniture.com

NATIONAL OUTDOOR FURNITURE, INC.
 144 Murdock Road #325 Pomfret Center, CT 06259
 Toll-Free Phone: 1-888-516-8873
 Phone: 1-860-974-1551 Fax: 516-706-1901
 Email: nofinc@earthlink.net
www.nationaloutdoorfurniture.com