



Wood Planks

2" x 10" and 2" x 4" sizes
Rounded Edges
#1 Southern Yellow Pine

(U) Untreated
(PT) Pressure Treated
Environmentally Friendly ACQ
Kiln Dried Before & After Treatment
(T) Treated Stain
Sealed in Redwood Stain With
Wood Preservative

Standard Powder Coat Colors



8' Heavy Duty Wood Picnic Table -Portable.

- 226 - 278 Lbs.
- Overall Dimensions: 96"L x 62"W x 30"H..
- Frame available in 1 5/8" and 2 3/8" O.D. pipe with 1 5/16" O.D. brace.
- All MIG welded frame with zinc or galvanized plated hardware.
- Pre-drilled holes for surface mounting frame.
- Zinc coated, galvanized, powder coated or galvanized legs.
- Without umbrella hole.
- Available in 2" x 10" untreated pine, treated pine and redwood stained pine planks.
- Some assembly required.

Item #: US 158-8

Number	Description
US 158-U8	8' Table, 1 5/8" O.D. Pipe, Untreated Pine, Portable.
US 158-PT8	8' Table, 1 5/8" O.D. Pipe, Treated Pine, Portable.
US 158-T8	8' Table, 1 5/8" O.D. Pipe, Redwood Stained Pine, Portable.
US 238-U8	8' Table, 2 3/8" O.D. Pipe, Untreated Pine, Portable.
US 238-PT8	8' Table, 2 3/8" O.D. Pipe, Treated Pine, Portable.
US 238-T8	8' Table, 2 3/8" O.D. Pipe, Redwood Stained Pine,



National Outdoor Furniture
1210 W. Main Street #296
Riverhead, N.Y. 11901

PHONE (888) 663-4621
E-MAIL nofinc1@gmail.com
www.nationaloutdoorfurniture.com

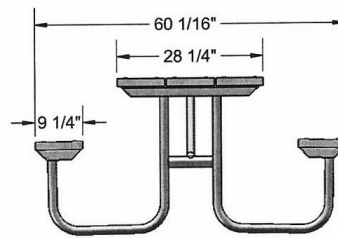
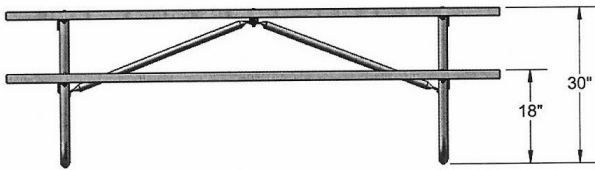
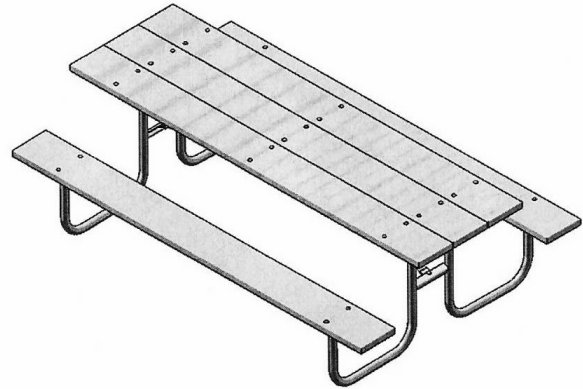
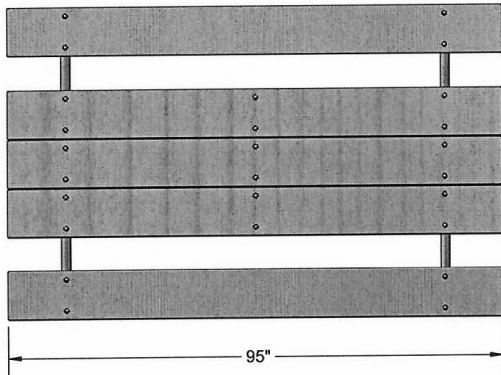

National Outdoor Furniture
1210 W. Main Street #296
Riverhead, N.Y. 11901

PHONE (888) 663-4621
E-MAIL nofinc1@gmail.com

www.nationaloutdoorfurniture.com