



**Havana Classic Stacking Armchair.**

- Master pack 4 and 12.
- Made of 100% simulated wicker resin.
- 12.42 Lbs. each.
- 23.5"W x 17.5"D x 35.5"H.
- Powder coated aluminum legs.
- ASTM F 1561 Class B commercial rating. UV inhibitors.
- Rated to 300 Lbs. For safe use in commercial environments.
- \$50.00 charge for orders under \$500.00.
- \$50.00 charge for quantities other than the master pack.

**Item #:** GR HCCAC



Bronze



French Taupe

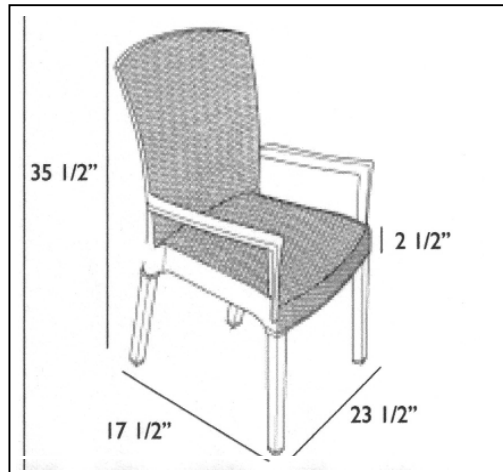

Charcoal